

All information on this drawing is proprietary and may not be reproduced in any manner or made available to any unauthorized person/party without written permission of ALPHA PRODUCTS, INC.



CUSTOMER APPROVAL	
SIGNATURE _____	DATE _____

REVISIONS			
REV.	DESCRIPTION	DATE	APPROVED

- MARKING:
- BAGGING:
- UPACKING:
- LOGO (ALPHA ONLY):
- FULL LOGO:

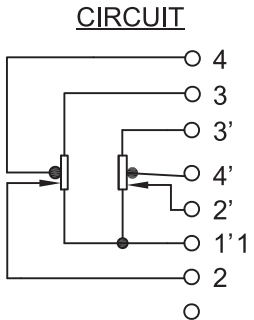
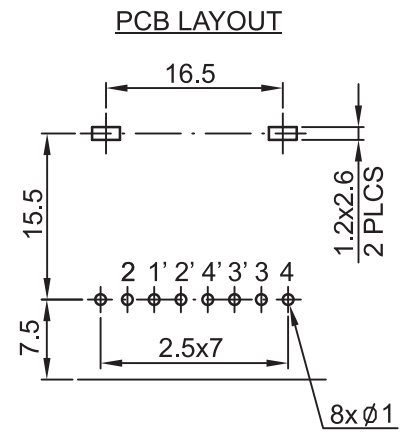
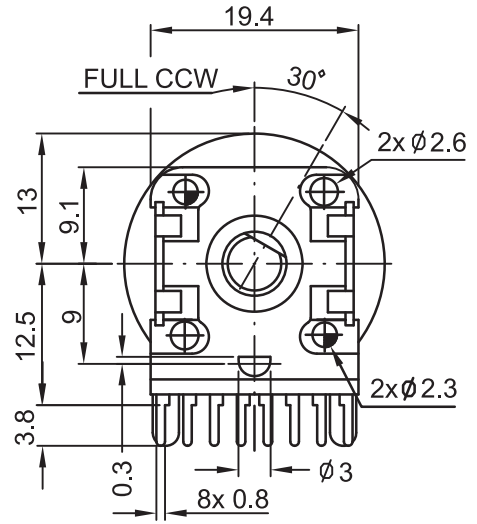
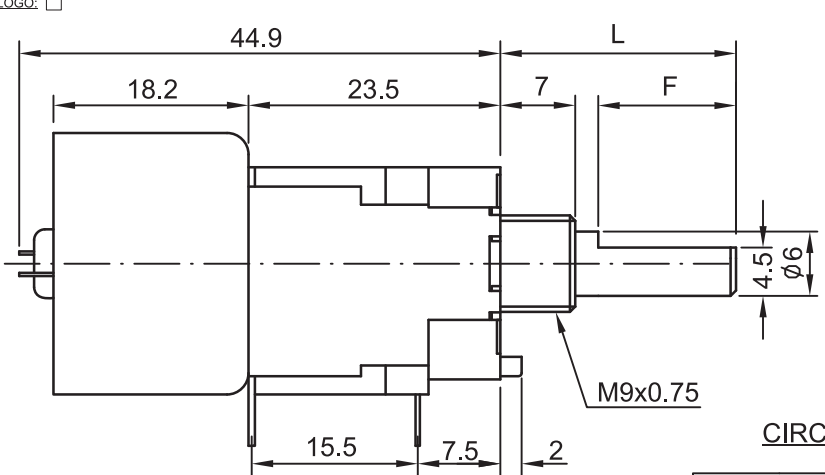

SPECIFICATIONS:

1. TOTAL RESISTANCE: 2K ~ 470K +/-20%
2. TAPER: A (AUDIO), B (LINEAR)
3. TOTAL ROTATIONAL ANGLE: 300 DEG. +/-10 DEG.
4. RATED POWER: TAPER A: 0.1W, TAPER B: 0.2W
5. OPERATING VOLTAGE: TAPER A: 150V MAX, TAPER B: 200V MAX
6. OPERATING CURRENT OF MOTOR SECTION: 150mA MAX
7. INSULATION RESISTANCE: 100MOhm @250V DC MIN
8. WITHSTAND VOLTAGE: 250V AC FOR 1 MINUTE
9. ROTATIONAL SPEED: 11+/-3 SEC. @4.5V DC
10. LIFE: 10,000 CYCLES

AVAILABLE SHAFT LENGTH				
DIM "L"	15	20	25	30
DIM "F"	6	8	10	12

1. ALL DIMENSIONS ARE IN MM.
NOTES:

VCN	CCN	AGE
APPLICATION		

ITEM #	QTY REQD.	UNIT MEASURE	PART OR IDENTIFYING NO.	NOMENCLATURE OR DESCRIPTION	MATERIAL SPECIFICATION
PARTS LIST					
TOLERANCES (UNLESS OTHERWISE SPECIFIED)			CONTRACT NO.		
MATERIAL			APPROVALS		DATE
FINISH			DRAWN		G.S. 01/23/14
			CHECKED		R.G. 01/23/14
			ISSUED		
SIZE		FSCM NO.	DWG NO.		REV.
B		8U759	300/RC041000		
SCALE			NONE		SHEET 1 OF 1

ALPHA PRODUCTS, INC.
351 IRVING DR, OXNARD, CA 93030 USA
TEL: (805)981-8666 FAX: (805)988-6555
E-MAIL: info@alpha-products.com

POT, MOTORIZED, 16MM, D-SHAFT, W/TAP, PCB